

International Conference on Space Optics—ICSO 2018

Chania, Greece

9–12 October 2018

Edited by Zoran Sodnik, Nikos Karafolas, and Bruno Cugny



A flight demonstration photonic payload for up to Q/V-band implemented in a satellite Ka-band hosted payload aimed at broadband high throughput satellites

Miguel Piqueras

Javier Martí

Silvia Delgado

Rob Singh

et al.



A Flight Demonstration Photonic Payload for up to Q/V-Band implemented in a satellite Ka-Band hosted payload aimed at Broadband High Throughput Satellites

Miguel A. Piqueras^a, Javier Martí^a, Silvia Delgado^b, Rob Singh^b, Dan Beeder^b, Robert Parish^b, Ghislain Turgeon^b, Antoni Castells, Laurent Roux^c

^aDAS Photonics, Camino de Vera s/n, Edificio 8F, 46022, Valencia, Spain; ^bSSL, 3825 Fabian Way, M/S G-10, Palo Alto, CA, USA 94303; ^cEutelsat, 70 Rue Balard, F-75502 Paris Cedex 15, France

ABSTRACT

This paper provides a summary on the design, parameter allocations and testing of a Ka-band Flight Demonstration Photonic Payload aimed for payload solutions from Ku up to Q/V Band High Throughput Satellites (HTS) Systems. The paper describes the system and payload design overviews, identifies payload hardware, and summarizes key unit and payload performances for the Ka-Band Flight demonstration payload. The in-flight demonstration is now integrated as a hosted payload in a GEO communications satellite that is following spacecraft level integration and testing in preparation for launch. This hosted payload once on orbit will demonstrate the photonics technology and will perform an on orbit Ka-Band transmission/reception function with performance characterization and demonstration of operational capabilities.

Keywords: Photonic Payload, High Throughput Satellites, Q/V band, Ka band, Flight Demonstration, Frequency Conversion

1. INTRODUCTION

Historically reductions in cost per Gbit/sec have been achieved through increasing payload power or increasing satellite design life. A recent trend has also been towards multibeam missions with increased mission capacity through the application of frequency re-use in multi-beam antennas to provide high speed connectivity and broad coverage. The major bottlenecks for the adoption of these technologies are the increase of the size, weight and power consumption. Currently operators already require a 10-fold increase of total payload capacity (in the order of the Tb/s) delivered with today's satellite platforms (named Ultra High Throughput Satellites – UHTS). As the operators push for more and more capacity it is well understood today that conventional RF and microwave technology cannot satisfy the explosion of capacity requirements.

In that sense, the addition of two new technologies to the present multi-beam architectures could be the key to address the challenges of providing up to 10-fold capacity at similar size-mass-power envelop:

- The use of high frequency Q & V bands, with large bandwidth available in the link with the gateways
- The use of photonic technology in the payloads addressing the functionalities of frequency conversion, signal and LO routing with forecasted reduction in one order of magnitude in mass, power consumption and footprint.

DAS Photonics in collaboration with SSL (a Maxar Technologies company) has developed a V/Q Broadband Photonic Converter Assembly (PCA). The PCA represents a single string configuration or single frequency conversion based on a single Local Oscillator (LO). The PCA is aimed to be a representative building block of a multi-string payload configuration or assembly performing multiple frequency conversions from multiple LOs. A PFM unit has been used in a hosted payload demonstrator denominated Single String Photonics Payload (SSPP) operating at Ka-Band.

The DAS Photonics product will be used within the low power section of this SSL telecom payload to provide a generic solution for any SATCOM operating frequency enabling broadband multi-frequency conversion from L-band to V-band. This product should open the door to simplify the design and implementation of future telecom payloads, especially for ultra-high throughput satellites.

The design has been optimized to cover up to V band at the RF input and Q band at IF output, although the frequency conversion is broadband in the sense that almost any RF, IF and LO frequencies can be supported covering the typical

SATCOM frequency bands. The SSPP is understood as a broadband mixer also applicable to up-conversion. No channel filtering is included as part of the SSPP (either electrical or photonic), so external filters will set the final functionality of the string (up or down converter, and in which frequency).

The Q-Band (40GHz) and V-Band (50GHz) frequency spectrums are being considered for satellite communication systems to help with issues related to an already crowded Ka-Band frequency spectrum placing limitations on achievable system capacity. To utilize the V and Q band spectrum for commercial satellite payloads, high performance, space-qualified, millimeter-wave components will be required

2. EUTELSAT 7C SATELLITE

This DAS optical hardware is part of a SSL Ka-band hosted payload in the SSL manufactured satellite for EUTELSAT, as EUTELSAT 7C. Its broadband capability was tested on ground up to the Q and V bands per de design requirements for an universal, broadband photonic frequency converter to be able to operate at any SATCOM frequency band from Ku to V band for future payloads with multiple LOs and frequency conversions.

3. PHOTONIC PAYLOAD CONCEPT FOR HTS

SSL and DAS Photonics are pursuing the introduction of payload equipment based on photonic technology within the commercial satellite market and are developing an architecture concept named V/Q-Band Photonic Converter Assembly (V/Q-PCA), which is **intended to fulfil the UHTS needs** with the following features:

- Use of photonic technology for the generation of multiple Photonic Local Oscillator and for its distribution via optical fibre.
- Use of **photonic technology for the multiple, simultaneous signal mixing** (RF conversion to IF with a photonic Local Oscillator) **in a single device**, which enables the reduction in the amount of equipments.
- Use of **photonic technology for the demultiplexing and routing of the different frequency conversions** (associated to multiple LOs). A schematic view of these characteristics is shown in **Figure 1**.
- **Implementation of ultra-broadband electro-photonic interfaces covering from Ku to V band in a generic solution**, which enables to have a single photonic solution for any frequency band. This concept simplifies the architecture and reduces the need of “payload personalization” to the RF interfaces.
- Use optical fibre within a distributed architecture enables satellite designers to have a new degree of freedom and flexibility in the allocation of the hardware thanks to the following characteristics of the optical fibre:
 - o The propagation losses are independent of the lengths required in a satellite
 - o Optical fibre is completely immune to RF interference so it can be routed freely
 - o The mass of the optical fibre is much smaller than coaxial cables and RF waveguides and is easy to route and bend.
 - o Optical fibre can multiplex many channels/signals in a single fibre by using wavelength (de)multiplexing schemes (WDM) so the number of fibres can be reduced compared to RF cables (for example, all the LOs required in the architecture are multiplexed in a single fibre: the RF counterpart is to have a dedicated LO distribution network for every single LO).

The product is a **Broadband Photonic Frequency Converter** from V/Q/Ka to Q/Ka band with photonic LO Module. The main modules of the product are:

- Generic, **broadband LO** remotely delivered by optical fiber covering LO frequencies up to 32.8 GHz.
- **Broadband frequency conversion** (Ph DOCON module) operation of photonic E/O converters able to operate at any frequency up to V-band
- **Coupler and splitter (C&S) Module**, it comprises all the passive optical devices, optical splitters, couplers and multiplexers for the distributed architecture in charge of aggregating the different photonic LOs and providing the splitting ratio required for the architecture.
- **Photo-receiver** up to 50GHz, which converts the optical signal into RF. Its key device is a RF photodiode, which should cover well up to V-band, required for the gateways uplink signals in the forward link for the future HTS payloads.

- **De-multiplexer** is the responsible for the signals de-multiplexing. This module comprises the following key components:

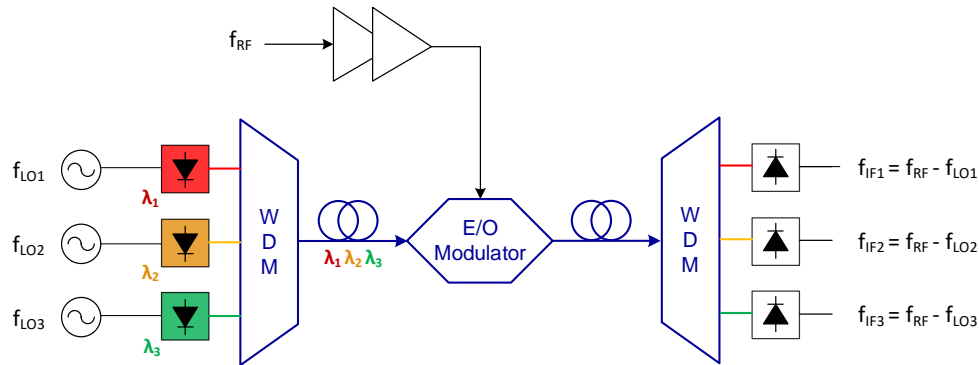

Figure 1 – Concept of photonic frequency conversion with multiple LOs. Simplified scheme with 3 LOs modulated in three optical carriers, multiplexed (wavelength multiplexing), simultaneous mixing with the RF signal in an electro/optical mixer, demultiplexed and photodetected.

The architecture described and the associated modules are what is named Multi-String Photonic Payload (MSPP) and the fundamental idea is to build generic photonic modules with RF interfaces able to cover either the future UHTS architectures (in V/Q and Ka to/from Ka/Ku band) and the more conventional ones (in Ka and Ku band), not requiring modification from one satellite to other (eventually minor changes). To do so, a first iteration is to demonstrate the key functionalities that are the core of the concept, let's say electro-optical-conversion up to Q/V bands, frequency conversion, optical amplification and fiber-optics remote delivery, and the implementation of a single chain of the architecture that integrates all these functionalities and components in a simplified enclosure. A view of the Single String Photonic Payload (SSPP) is shown in the Figure 2, including internal block diagram and proposed mechanical enclosure.

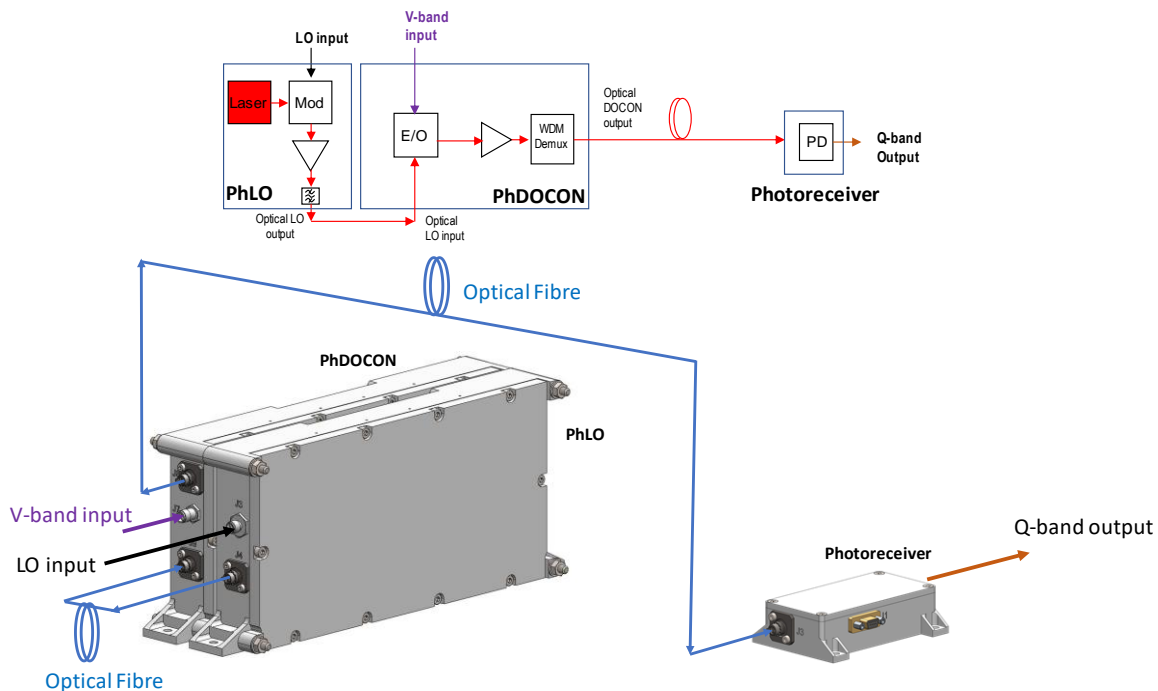

Figure 2 – Single String Photonic Payload: block diagram (top) and mechanical enclosure (bottom)

The SSPP is a distributed system composed of three assemblies interconnected by optical fiber. Each assembly has its own DC power and TM/TC interfaces, as well as specific optical and electrical ports. These assemblies are:

- Photonic Local Oscillator Assembly (PhLO)

- This assembly generates the optical local oscillator used in the photonic frequency conversion process.
- Basically, it is an optical transmitter that converts an electrical Local Oscillator to the optical domain.
- Photonic Modulator Assembly or Photonic Downconverter (PhDOCON)
 - This assembly is basically a photonic mixer that mixes the photonic LO with an RF signal to generate a set of mixing products.
 - The mixing process is done by an optical modulator that mixes the RF signal into the photonic LO.
 - This assembly integrates also optical amplification and optical filters for signal conditioning.
- Photonic Receiver Assembly (PhRx)
 - It is composed fundamentally of a broadband photodetector and the associated circuitry.
 - The optical signal with the multiple mixing products generated in the PhDOCON is converted from optical to electrical in a homodyne detection process.
 - The desired mixing product is selected by an IF filter at the PhRx output.
 - This filter is not part of the SSPP. This allows the SSPP to be used at any RF, LO and IF frequency.

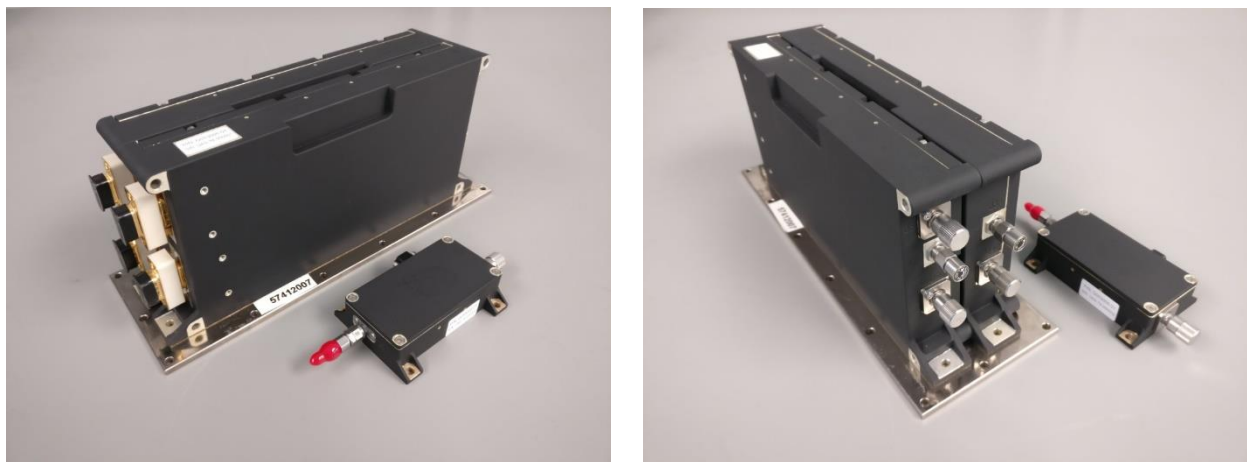

Figure 3 - Picture of the SSPP PFM. The PhLO and PhDOCON are stacked together in a single assembly. The connection between the units is done by optical fiber (not shown in this picture).

PhLO and PhDOCON are attached together to form a single unit, while the Ph-Receiver will be an independent unit. Photos of the SSPP PFM are shown in the Figure 3.

4. PHOTONIC PAYLOAD QUALIFICATION

The photonic payload has been submitted to a qualification campaign according with the requirements for a 15-years GEO missions, which included the following tests at module level:

- Thermal Vacuum Test
- Shock Test
- Vibration Test (see Figure 4)
- EMC and ESD test
- Functional test.

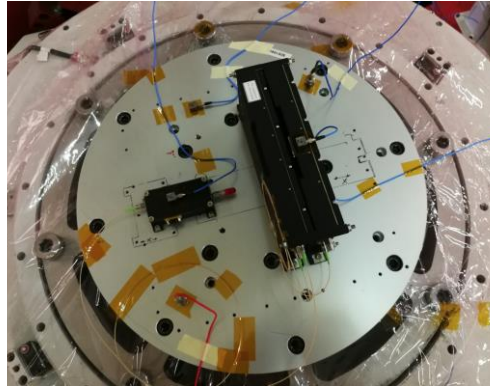

Figure 4 - Test set-up for Y axis vibration at INTA facilities (Spain)

The hardware was constructed with Level 1 Hi-Rel EEE and RF parts. The photonics components were up-screened to build a set of photonic flight parts from lots of Telcordia-based parts in some cases, and from custom made components in other cases. The flight lot was qualified according to a program designed by SSL and DAS teams and in accordance with ECSS and NASA standards as well as SSL internal procedures. The test flow for the flight parts is shown in the Figure 5.

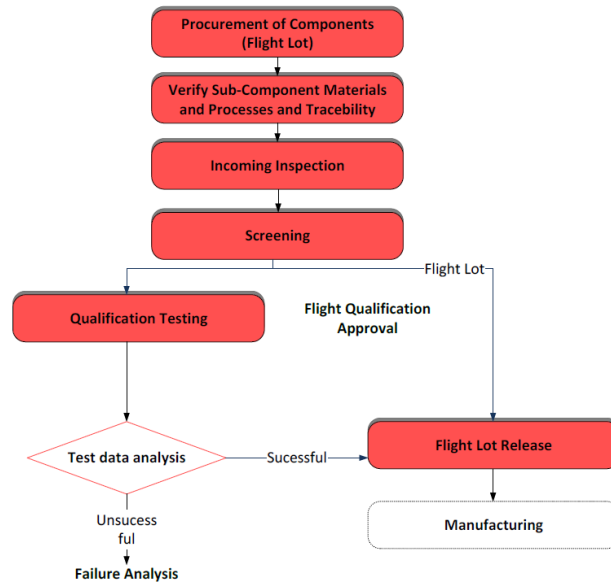

Figure 5 - Qualification Test Flow for production

The photonic parts up-screening test sequence based upon MIL, Telcordia and ECSS standards was the following:

- High Temp Stabilization Bake
- Temperature Cycling (MIL-STD-883)
- Mechanical shock (MIL-STD-883)
- PIND (MIL-STD-883/2020)
- Initial Electrical (relevant tests)
- Burn-in (Max rated temp, appropriate conditions)
- Final Electrical, including test over temperature (min, room, max)
- Parameter Drift (room temperature)
- External visual

The qualification of the flight lot included the following tests on a set of up-screened samples:

- Lot Qualification Life test
 - Maximum rated temperature or dissipated power
 - Initial 2000-hour test
 - Endurance to 8000 hours or failure
- Lot Qualification Radiation test
 - TID stepped up to 150 kRad
 - Proton stepped testing at 60 MeV
 - Testing of relevant parameters before and after each irradiation step
 - Calculating parameter drifts
- Lot Qualification Destructive Physical Analysis (DPA)
 - according MIL-STD-1580B
 - including constructional analysis as per MIL-STD-883 and ECSS.

5. RF TRANSFER PERFORMANCE

The RF transfer parameters have been tested in Ka band for the final configuration implemented in the SSPP PFM to be hosted on E7C. The capabilities of the unit to be operated in different frequencies (Ka and Q/V) were assessed as well. More specifically, the Ka band tested frequencies were:

- Input frequency: 27.1 to 31 GHz
- Output Frequency: 17.3 to 21.2 GHz
- LO frequency: 9.8 and 10.2 GHz

And the Q/V band frequencies tested were:

- Input frequency: 47.2 to 51.4 GHz
- Output Frequency: 37.4 to 41.6 GHz
- LO frequency: 9.8 GHz

5.1 Conversion Gain

The following figure shows the gain tested at different LO and RF input powers, converting from minimum to maximum LO power (+8.5 to +10.5 dBm) and the minimum, maximum and absolute maximum (-31, -8 and -5 dBm) of the RF input power. The minimum gain at ambient in all the configurations was higher than -12.5dB and -12.1dB at hot.

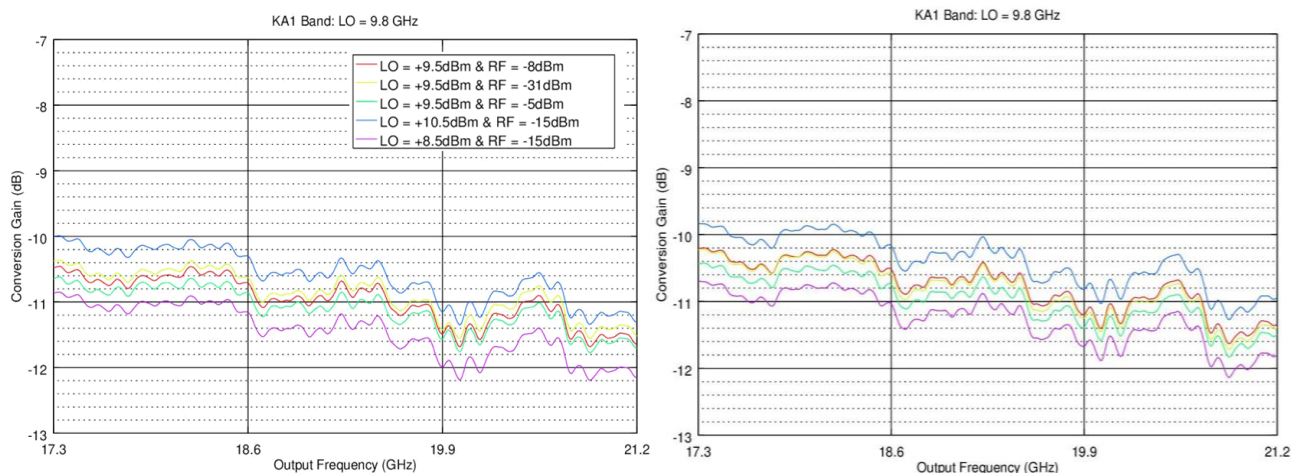

Figure 6 – Conversion gain at ambient temperature (+25°C) (*left*) and at hot (65°C) (*right*) in Ka-band

5.2 RF input power range

The gain compression has been measured for different LO powers and temperatures. The following figure shows the gain compression at 14°C (close to ambient) and -10°C (cold case). The gain (S21) is constant up to approximately -10dBm of

input power and then the gain starts to compress, being the 1dB input compression point higher than 0dBm (around 2 dBm).

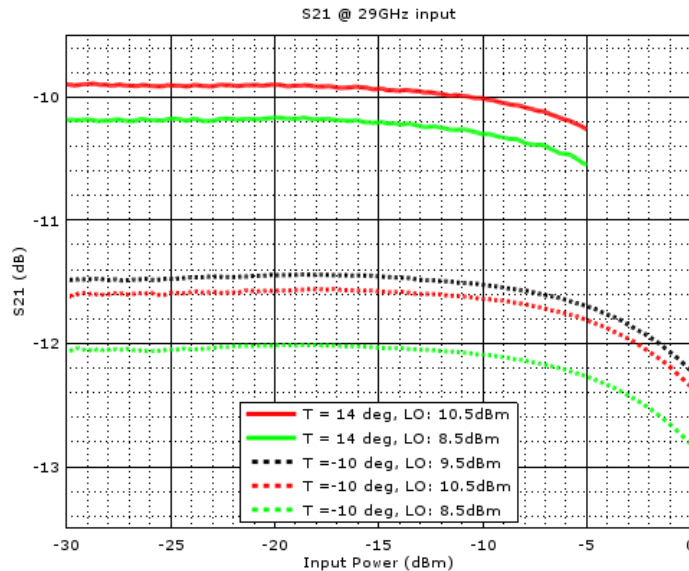

Figure 7 – Gain compression vs input RF power at different temperatures (14 and -10°C)

5.3 Noise Figure

The following figures include the noise figure tested at different temperatures for the Ka-band and at ambient temperature at V-band.

For the Ka-band, at soft cold, cold and hot temperatures this measurement was also carried out for different LO input powers, covering from minimum to maximum LO powers (+8.5 to +10.5 dBm). The maximum noise figure at ambient, soft cold, cold, soft hot and hot are 40dB, 40 dB, 41.1dB, 39.5dB and 40.5 dB respectively.

The Noise figure tested at V-band input, Q-band output at ambient temperature was lower than 40 dB with LO input power of +10dBm.

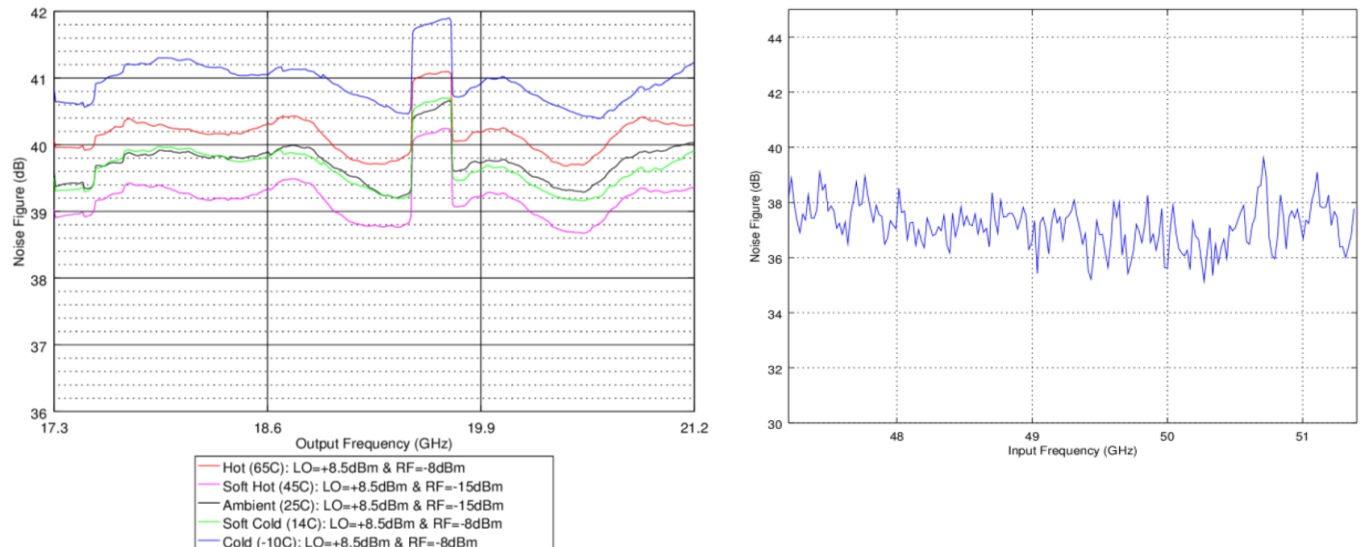

Figure 8 - Noise figure vs output frequency for Ka-to-Ka band (left) and from V-to-Q band (right). Ka-band tested at different temperatures and RF input powers. V-band tested at ambient temperature.

5.4 Third Order Linearity

The table below summarizes the measured third order linearity performance for the two Ka-bands flight LO frequencies and the RF input frequencies at -11dBm per carrier (dual carrier test). A screenshot of one test is shown in Figure 9:

Band	Temperature	LO input <i>Frequencies & power/carrier</i>	RF input <i>Frequencies & power/carrier</i>	C/3IM (dBc)	OIP3 (dBm)
Ka1	Ambient	9.8GHz @ 9.5dBm	27.1 & 27.12GHz @ -11dBm	>58.1	>6.2
			29 & 29.02GHz @ -11dBm	>61.2	>9.3
			30.98 & 31GHz @ -11dBm	>59.8	>8.1
Ka2	Ambient	10.2GHz @ 9.5dBm	27.55 & 27.57GHz @ -11dBm	>59.7	>7.3
Ka1	Hot	9.8GHz @ 9.5dBm	27.1 & 27.12GHz @ -11dBm	>59.3	>8.2
			29 & 29.02GHz @ -11dBm	>60.4	>6.9
			30.98 & 31GHz @ -11dBm	>63.7	>8.3

Table 1 – Third order linearity at different RF input frequencies and temperatures for Ka1 & Ka2 frequencies.

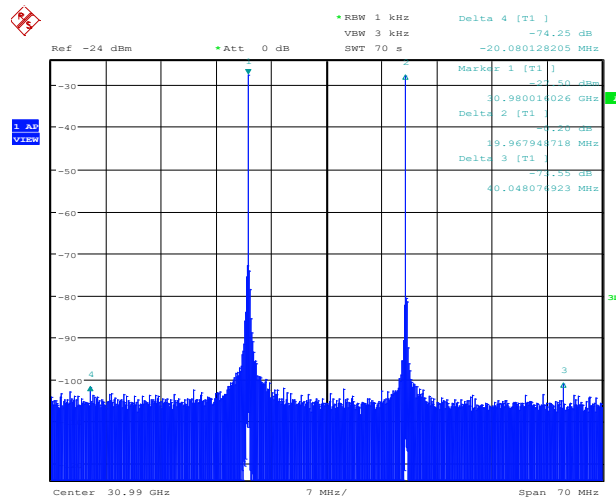

Figure 9 – Ka1 band RF C/I at cold temperature (30.98 & 30 GHz input frequencies)

6. CONCLUSION

The first Photonic Local Oscillator and photonic frequency converter able to operate up to V/Q band has been designed, manufactured, tested and integrated into a commercial telecom satellite. Though it was tested on the ground up to V/Q band, due to its broadband characteristics it will be operated in orbit at Ka-band. The photonic suite is able to work with LO frequencies beyond 35GHz and RF input/output frequencies beyond 51.4/42.5 GHz. The interconnection among the photonic modules (LO, DOCON, Receiver) is achieved through optical fiber, which replaces of segments of waveguides and/or coaxial cables in the payload, thus reducing the overall mass and footprint of the RF harness.

The photonic units have been designed and constructed following the standard requirements for a 15-years missions in GEO orbit and has been qualified at module level with a qualification vehicle (qualification-like model). A specific process for up-screening and qualification of the photonic parts (not available in hi-rel, rad-hard version) has been designed and implemented.

Functional test results have demonstrated the broadband operation of the photonic solution and its suitability for commercial telecom satellites, especially for HTS in which a large optimization of mass, size and power consumption is foreseen with respect to a traditional RF implementation.